

This assembly consists of a 30 PSI check and a pilot-operated, balanced-piston relief cartridge which is a normally closed pressure regulating valve. When the pressure at the inlet (P port) reaches the valve setting, the valve starts to open to tank (T port), throttling flow to regulate the pressure. These valves are accurate, have low pressure rise vs. flow, they are smooth and quiet, and are moderately fast. This assembly also incorporates an air-bleed and start-up cartridge which is used to purge air trapped in the system to help reduce power requirements and facilitate pump priming during the start-up of blocked center circuits.

**TECHNICAL DATA** NOTE: DATA MAY VARY BY CONFIGURATION. SEE CONFIGURATION SECTION.

Body Type	Line mount
Capacity	40 gpm
Check Cracking Pressure	30 psi
Mounting Hole Diameter	.41 in.
Mounting Hole C'bore Diameter	.59 in.
Mounting Hole C'bore Depth	.31 in.
Mounting Hole Quantity	2

- NOTES:**
- **Important:** Carefully consider the maximum system pressure. The pressure rating of the manifold is dependent on the manifold material, with the port type/size a secondary consideration. Manifolds constructed of aluminum are not rated for pressures higher than 3000 psi (210 bar), regardless of the port type/size specified.
  - For detailed information regarding the cartridges contained in this assembly, click on the models codes shown in the Included Components tab.

**OPTION SELECTION EXAMPLE: YFRCLANAL**

CONTROL		(L) ADJUSTMENT RANGE	(A) SEAL MATERIAL	(N)
<b>L</b>	Standard Screw Adjustment	<b>A</b> 100 - 3000 psi (7 - 210 bar), 1000 psi (70 bar) Standard Setting	<b>N</b> Buna-N	
<b>C</b>	Tamper Resistant - Factory Set	<b>B</b> 50 - 1500 psi (3,5 - 105 bar), 1000 psi (70 bar) Standard Setting	<b>V</b> Viton	
<b>K</b>	Handknob	<b>C</b> 150 - 6000 psi (10,5 - 420 bar), 1000 psi (70 bar) Standard Setting		
<b>W</b>	Hex Wrench Adjustment	<b>D</b> 25 - 800 psi (1,7 - 55 bar), 400 psi (28 bar) Standard Setting		
<b>Y</b>	Tri-Grip Handknob	<b>E</b> 25 - 400 psi (1,7 - 28 bar), 200 psi (14 bar) Standard Setting		
		<b>N</b> 60 - 800 psi (4 - 55 bar), 400 psi (28 bar) Standard Setting		
		<b>Q</b> 60 - 400 psi (4 - 28 bar), 200 psi (14 bar) Standard Setting		
		<b>W</b> 150 - 4500 psi (10,5 - 315 bar), 1000 psi (70 bar) Standard Setting		

**PRIMARY CARTRIDGE (A)**

<b>A</b>	A (with RPGC primary cartridge, Pilot-operated, balanced piston relief valve)
<b>A</b>	A (with RPGC3 primary cartridge, Non-adjustable pilot-operated, balanced piston relief valve)
<b>A</b>	A (with RPGC8 primary cartridge, Pilot-operated, balanced piston relief main stage with integral T-8A control cavity)

**INCLUDED COMPONENTS**

Part	Description	Quantity
500-001-113*	O-Ring	2
500-001-125*	O-Ring	1
CXFAXCN	Cartridge	1
NQEBXAN	Cartridge	1
RPGCLAN	Cartridge - Primary	1

**TECHNICAL FEATURES**

- Back pressure on the tank port (port 2) is directly additive to the valve setting at a 1:1 ratio.
- Air-bleed and start-up valves require a minimum of 4 gpm (15 L/min.) flow rate and 80 psi (5,5 bar) system pressure.
- The air-bleed and start-up valve will re-open when system pressure falls below 25 psi (1,7 bar)
- After air has been purged, closing times vary from approximately 12 seconds at 4 gpm (15 L/min.) to 0.5 seconds at 50 gpm 200 L/min.).
- Suitable for use in load holding applications.

# MANIFOLD FACES

## FACE GRID

1	2	3	4
5	6	7	8
9	10	11	12

## FACE 2

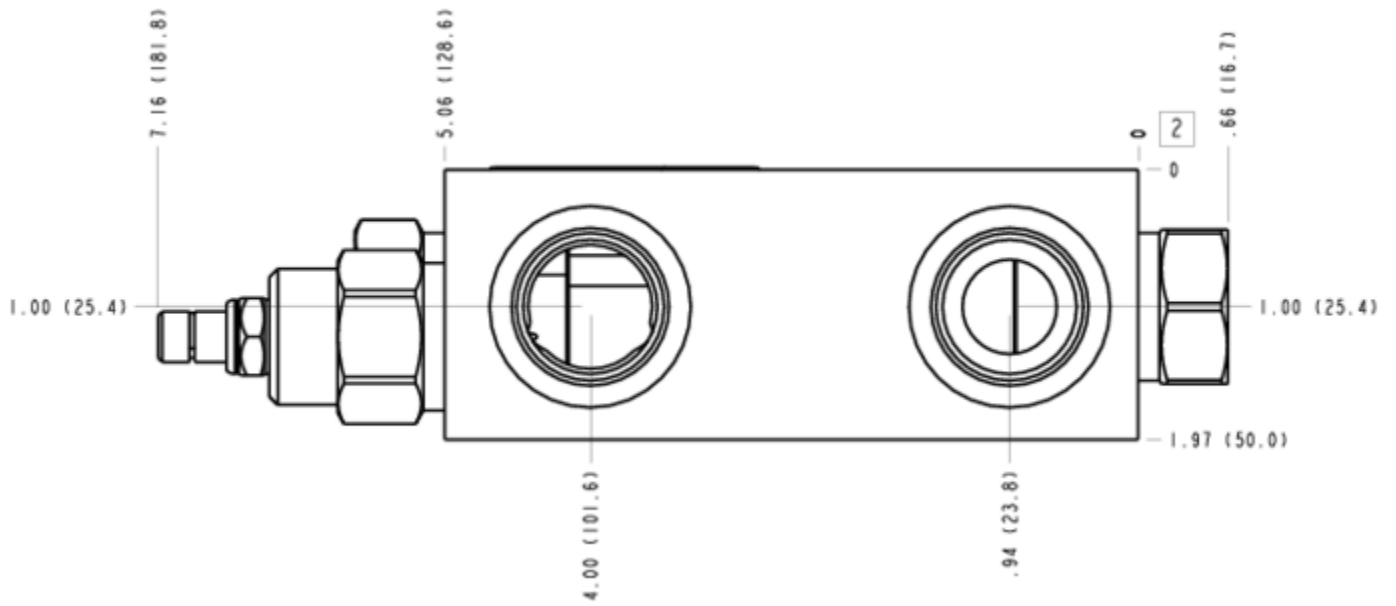

FACE 5

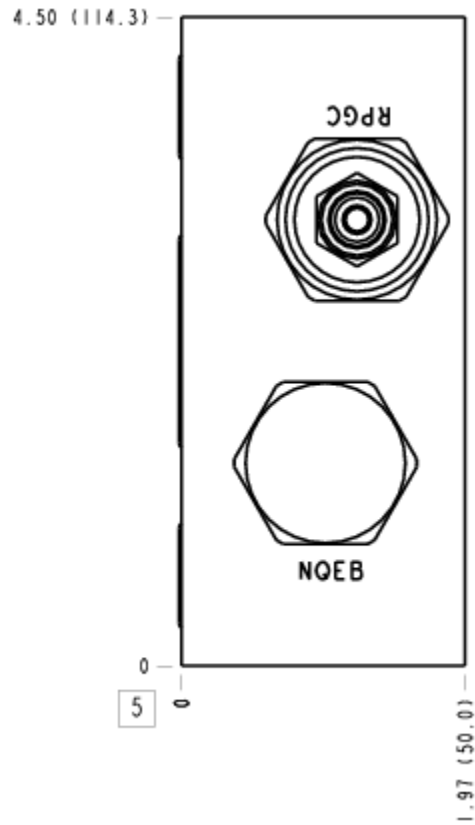

FACE 6

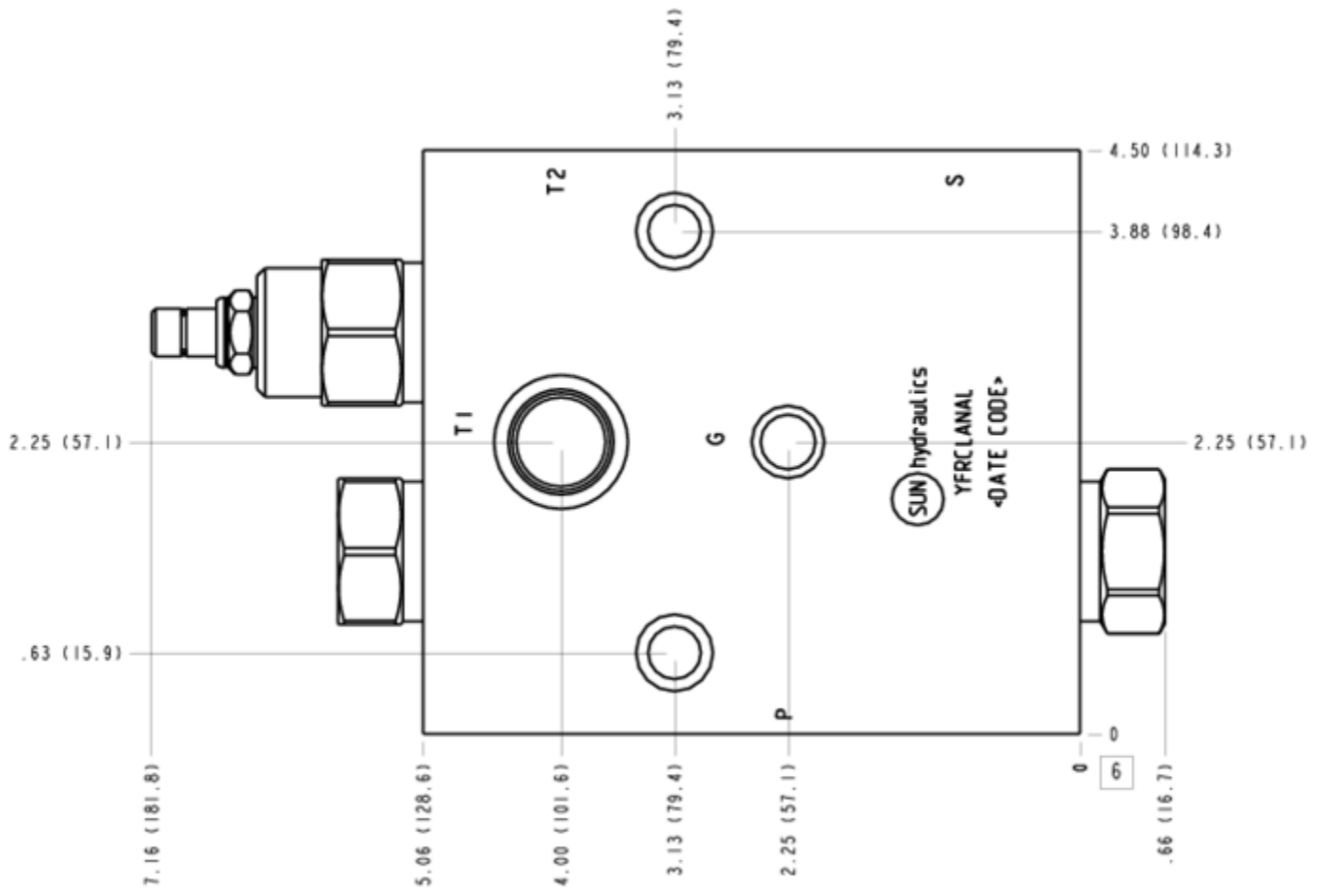

FACE 7

