

This valve assembly uses 3 divider/combiner valves to provide 4 equal bidirectional flows. In the dividing mode, flow coming into AB is divided into 4 equal flows, A1, A2, B1, B2. In the combining mode the assembly throttles the 4 flows coming into A1, A2, B1, B2 keeping them equal. The package provides error correction at the end of stroke in both directions.

TECHNICAL DATA NOTE: DATA MAY VARY BY CONFIGURATION. SEE CONFIGURATION SECTION.

Body Type	Line mount
Capacity	1.5 - 8 gpm
Mounting Hole Thread	.375-16 UNC - 2B in.
Mounting Hole Depth	.62 in.
Mounting Hole Quantity	2

- NOTES:**
- **Important:** Carefully consider the maximum system pressure. The pressure rating of the manifold is dependent on the manifold material, with the port type/size a secondary consideration. Manifolds constructed of aluminum are not rated for pressures higher than 3000 psi (210 bar), regardless of the port type/size specified.
 - For detailed information regarding the cartridges contained in this assembly, click on the models codes shown in the Included Components tab.

OPTION SELECTION EXAMPLE: YGCRXANAJ

CONTROL	(X) FLOW SPLIT	(A) SEAL MATERIAL	(N)
X Not Adjustable	A 50/50	N Buna-N	V Viton

PRIMARY CARTRIDGE	(A)
A (with FSCS primary cartridge, Synchronizing, flow divider-combiner valve)	

INCLUDED COMPONENTS

Part	Description	Quantity
A330-006-006*	SAE Plug	2
FSBSXAN	Cartridge	2
FSCSXAN	Cartridge - Primary	1

TECHNICAL FEATURES

- Operating characteristics cause the leg of the circuit with the greatest load to receive the higher percentage of flow in dividing mode. If a rigid mechanism is used to tie actuators together, the lead actuator may pull the lagging actuator and cause it to cavitate.
- In combining mode, compensating characteristics will cause the leg of the circuit with the lowest load to receive the higher percentage of flow. If a synchronization feature is not included, an additive accuracy error will be experienced with each full stroke of the actuator.
- In applications involving rigid mechanisms between multiple actuators, operating inaccuracy will cause the eventual lock-up of the system. If the mechanical structure does not allow for the operating inaccuracy inherent in the valve, damage may occur.
- In motor circuits, rigid frames or mechanisms that tie motors together, and/or complete mechanical synchronized motion of the output shaft of the motors, either by wheels to the pavement or sprockets to conveyors, will contribute to cavitation, lock-up and/or pressure intensification.
- Variations in speed and lock-up can be attributed to differences in motor displacement, motor leakage, wheel diameter variance and friction of wheels on the driving surface.
- Extreme pressure intensification can occur on multiple wheel drive vehicles.
- The synchronization feature provides bi-directional static error correction
- Synchronization flow is approximately 15% of minimum rated input flow.
- Differential slip for tractive drive systems must be achieved with orifices in the body/manifold.
- Divisional and combining accuracy are equal.
- The synchronizing feature only comes into play when any one of the 5 ports is blocked. At that time, synchronization flow may occur between the other four ports.
- Below the minimum flow rating there is not enough flow for the valve to modulate. It is effectively a tee. If flow starts at zero and rises, there will be no dividing or combining control until the flow reaches the minimum rating.

MANIFOLD FACES

FACE GRID

1	2	3	4
5	6	7	8
9	10	11	12

FACE 2

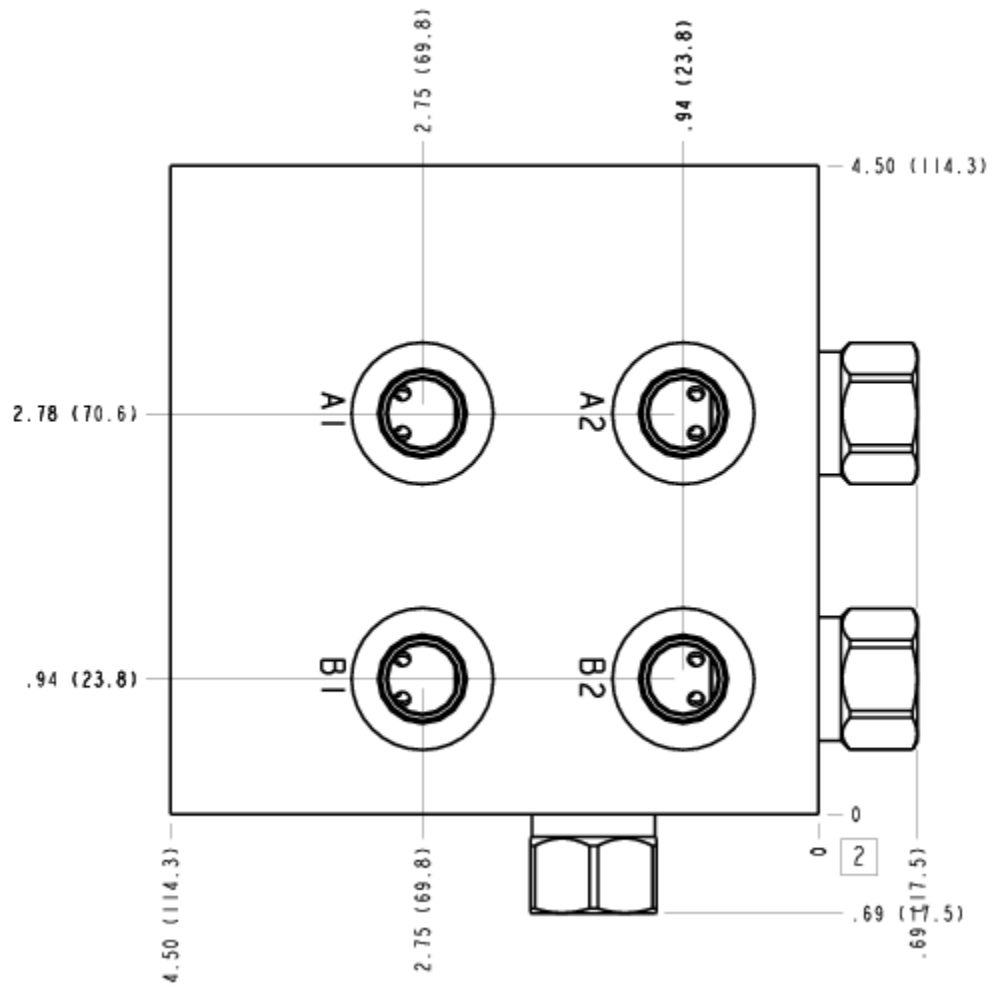

FACE 5

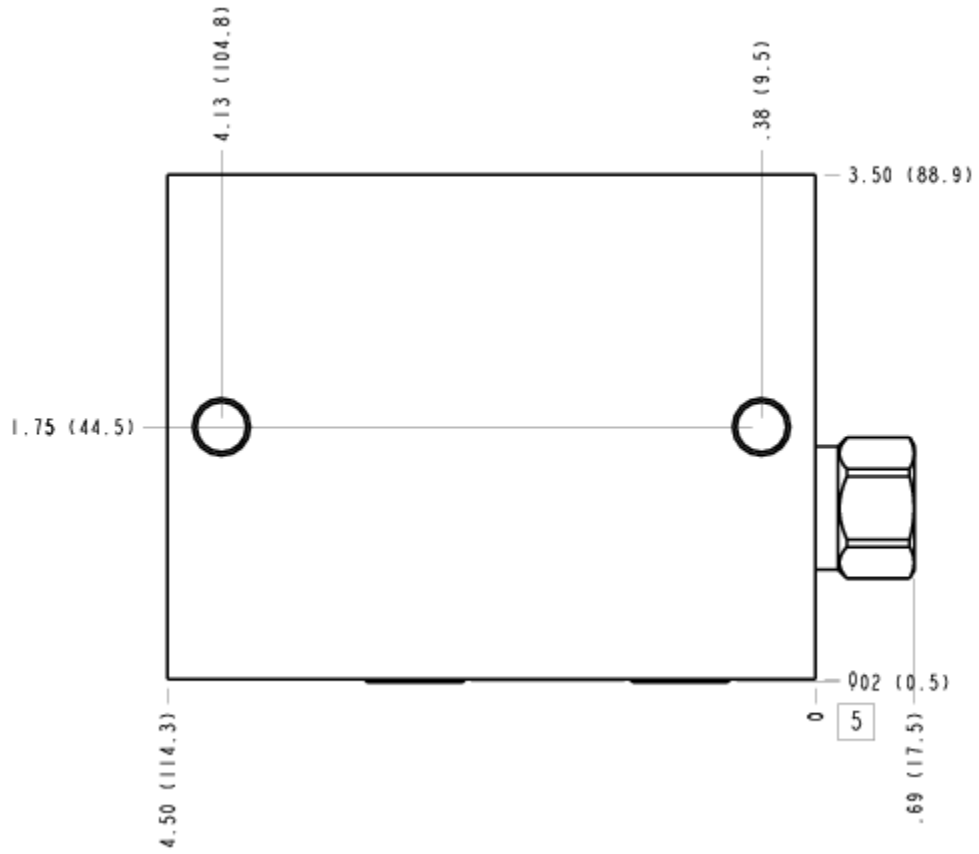

FACE 6

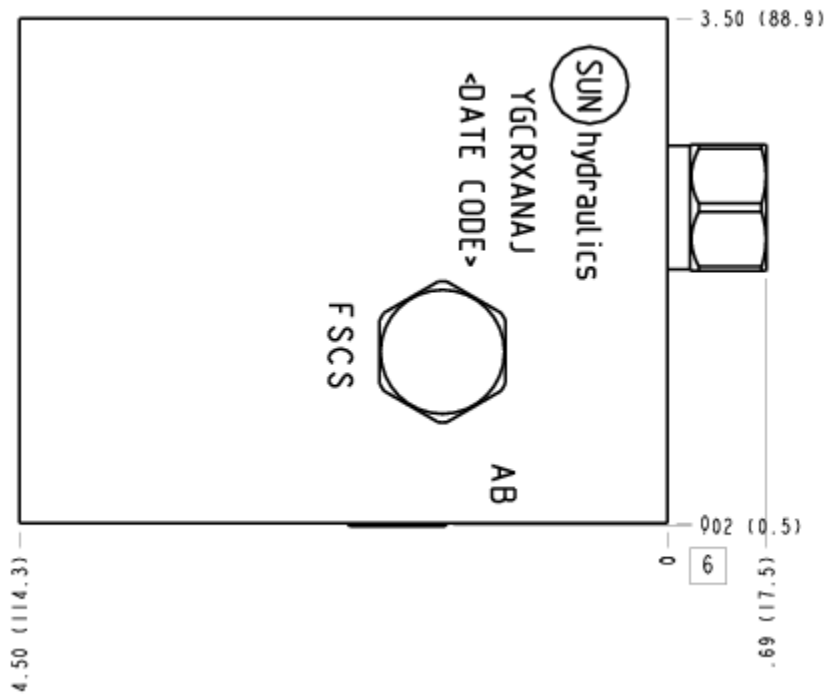

FACE 7

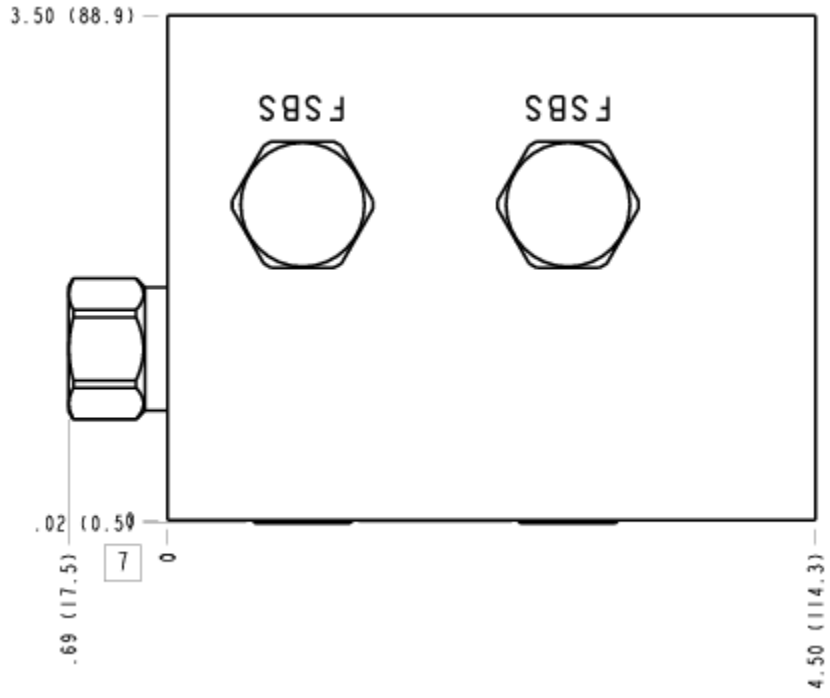

FACE 10

