

TECHNICAL DATA

Body Type	Line mount
Capacity	80 L/min.
Mounting Hole Diameter	7,1 mm
Mounting Hole Depth	Through
Mounting Hole Quantity	2

OPTION SELECTION EXAMPLE: YPECLANCK

CONTROL		(L) ADJUSTMENT RANGE	(A) SEAL MATERIAL	(N)	
L	Standard Screw Adjustment	A	100 - 3000 psi (7 - 210 bar), 200 psi (14 bar) Standard Setting	N	Buna-N
C	Tamper Resistant - Factory Set	B	50 - 1500 psi (3,5 - 105 bar), 200 psi (14 bar) Standard Setting	V	Viton
W	Hex Wrench Adjustment	D	25 - 800 psi (1,7 - 55 bar), 200 psi (14 bar) Standard Setting		
Y	manilla de tres agarres	E	25 - 400 psi (1,7 - 28 bar), 200 psi (14 bar) Standard Setting		
		N	60 - 800 psi (4 - 55 bar), 200 psi (14 bar) Standard Setting		
		Q	60 - 400 psi (4 - 28 bar), 200 psi (14 bar) Standard Setting		
		W	150 - 4500 psi (10,5 - 315 bar), 200 psi (14 bar) Standard Setting		

PRIMARY CARTRIDGE
(C)

C	30 psi (2 bar) (with PPF8 primary cartridge, Pilot-operated, reductor/alivio de presión válvula)
A	4 psi (0,3 bar) (with PPF8 primary cartridge, Pilot-operated, reductor/alivio de presión válvula)
B	15 psi (1 bar) (with PPF8 primary cartridge, Pilot-operated, reductor/alivio de presión válvula)
D	50 psi (3,5 bar) (with PPF8 primary cartridge, Pilot-operated, reductor/alivio de presión válvula)
E	75 psi (5 bar) (with PPF8 primary cartridge, Pilot-operated, reductor/alivio de presión válvula)
F	100 psi (7 bar) (with PPF8 primary cartridge, Pilot-operated, reductor/alivio de presión válvula)
Z	1 psi (0,07 bar) (with PPF8 primary cartridge, Pilot-operated, reductor/alivio de presión válvula)
Z	1 psi (0,07 bar) (with PPF8 primary cartridge, Pilot-operated, reductor/alivio de presión módulo principal con cavidad de control T-8A integral)
F	100 psi (7 bar) (with PPF8 primary cartridge, Pilot-operated, reductor/alivio de presión módulo principal con cavidad de control T-8A integral)
E	75 psi (5 bar) (with PPF8 primary cartridge, Pilot-operated, reductor/alivio de presión módulo principal con cavidad de control T-8A integral)
D	50 psi (3,5 bar) (with PPF8 primary cartridge, Pilot-operated, reductor/alivio de presión módulo principal con cavidad de control T-8A integral)
C	30 psi (2 bar) (with PPF8 primary cartridge, Pilot-operated, reductor/alivio de presión módulo principal con cavidad de control T-8A integral)
B	15 psi (1 bar) (with PPF8 primary cartridge, Pilot-operated, reductor/alivio de presión módulo principal con cavidad de control T-8A integral)
A	4 psi (0,3 bar) (with PPF8 primary cartridge, Pilot-operated, reductor/alivio de presión módulo principal con cavidad de control T-8A integral)

INCLUDED COMPONENTS

Part	Description	Quantity
CXEDXCN	Cartridge	1
PPFBLAN	Cartridge - Primary	1

MANIFOLD FACES

FACE GRID

1	2	3	4
5	6	7	8
9	10	11	12

FACE 2

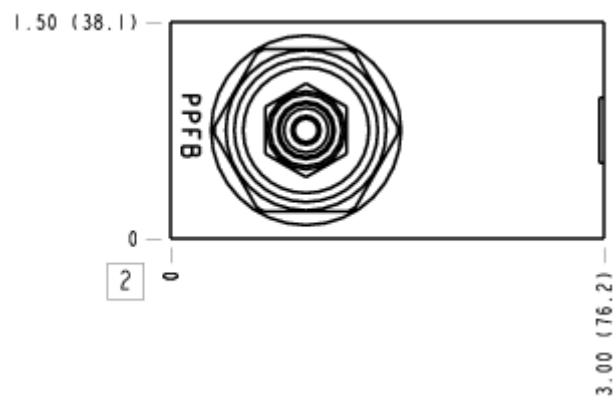

FACE 5

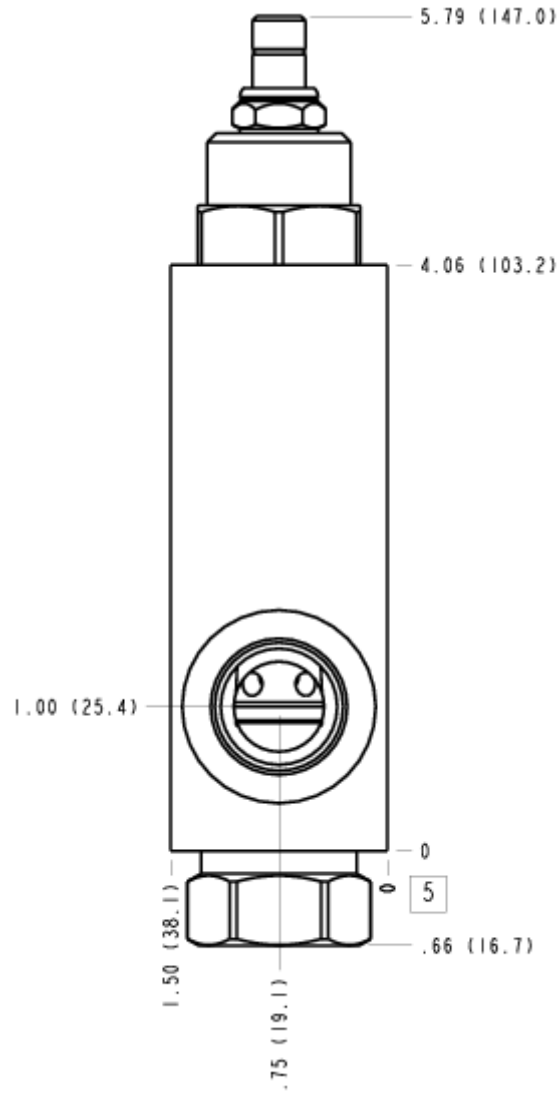

FACE 6

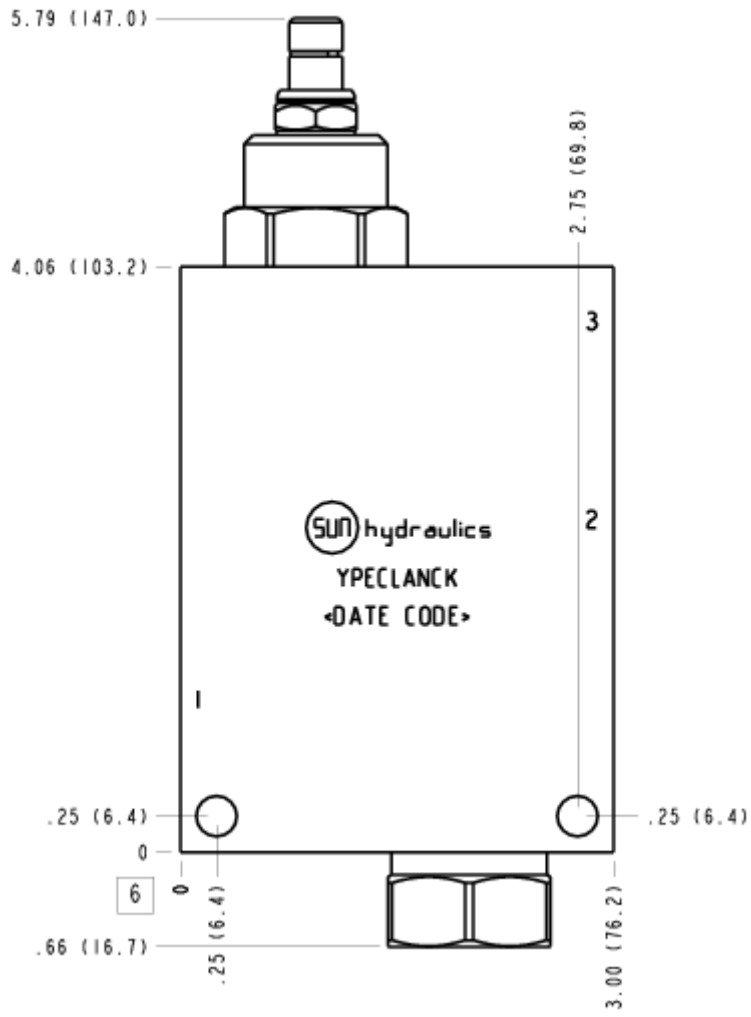

FACE 7

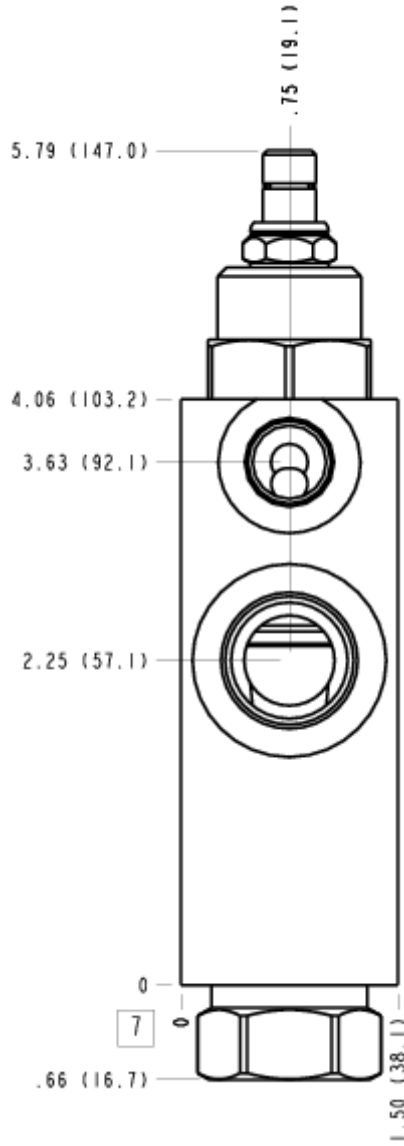

FACE 8

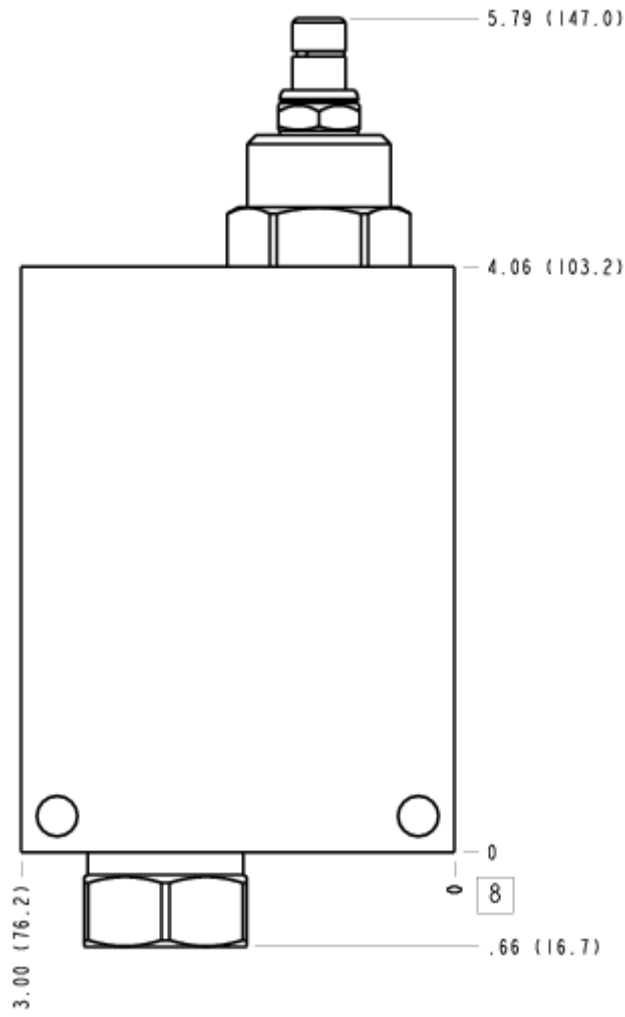

FACE 10

