

TECHNICAL DATA

Body Type	Line mount
Capacity	80 L/min.
Mounting Hole Diameter	7,1 mm
Mounting Hole Depth	Through
Mounting Hole Quantity	2

OPTION SELECTION EXAMPLE: YPFBLANCK

CONTROL	(L) ADJUSTMENT RANGE	(A) SEAL MATERIAL	(N)
L Standard Screw Adjustment	A 100 - 3000 psi (7 - 210 bar), 200 psi (14 bar) Standard Setting	N Buna-N	
C Tamper Resistant - Factory Set	B 50 - 1500 psi (3,5 - 105 bar), 200 psi (14 bar) Standard Setting	V Viton	
F Hex Head Screw with Locknut	C 150 - 6000 psi (10,5 - 420 bar), 200 psi (14 bar) Standard Setting		
W Hex Wrench Adjustment	D 25 - 800 psi (1,7 - 55 bar), 200 psi (14 bar) Standard Setting		
Y manilla de tres agarres	E 25 - 400 psi (1,7 - 28 bar), 200 psi (14 bar) Standard Setting		
	N 60 - 800 psi (4 - 55 bar), 200 psi (14 bar) Standard Setting		
	Q 60 - 400 psi (4 - 28 bar), 200 psi (14 bar) Standard Setting		
	W 150 - 4500 psi (10,5 - 315 bar), 200 psi (14 bar) Standard Setting		

PRIMARY CARTRIDGE

(C)

C 30 psi (2 bar) (with PBFB primary cartridge, Pilot-operated, reductor de presión válvula)
A 4 psi (0,3 bar) (with PBFB primary cartridge, Pilot-operated, reductor de presión válvula)
B 15 psi (1 bar) (with PBFB primary cartridge, Pilot-operated, reductor de presión válvula)
D 50 psi (3,5 bar) (with PBFB primary cartridge, Pilot-operated, reductor de presión válvula)
E 75 psi (5 bar) (with PBFB primary cartridge, Pilot-operated, reductor de presión válvula)
F 100 psi (7 bar) (with PBFB primary cartridge, Pilot-operated, reductor de presión válvula)
Z 1 psi (0,07 bar) (with PBFB primary cartridge, Pilot-operated, reductor de presión válvula)
Z 1 psi (0,07 bar) (with PBFB8 primary cartridge, Pilot-operated, reductor de presión módulo principal con cavidad de control T-8A integral)
F 100 psi (7 bar) (with PBFB8 primary cartridge, Pilot-operated, reductor de presión módulo principal con cavidad de control T-8A integral)
E 75 psi (5 bar) (with PBFB8 primary cartridge, Pilot-operated, reductor de presión módulo principal con cavidad de control T-8A integral)
D 50 psi (3,5 bar) (with PBFB8 primary cartridge, Pilot-operated, reductor de presión módulo principal con cavidad de control T-8A integral)
C 30 psi (2 bar) (with PBFB8 primary cartridge, Pilot-operated, reductor de presión módulo principal con cavidad de control T-8A integral)
B 15 psi (1 bar) (with PBFB8 primary cartridge, Pilot-operated, reductor de presión módulo principal con cavidad de control T-8A integral)
A 4 psi (0,3 bar) (with PBFB8 primary cartridge, Pilot-operated, reductor de presión módulo principal con cavidad de control T-8A integral)

INCLUDED COMPONENTS

Part	Description	Quantity
CXEDXCN	Cartridge	1
PBFBLAN	Cartridge - Primary	1

MANIFOLD FACES

FACE GRID

1	2	3	4
5	6	7	8
9	10	11	12

FACE 2

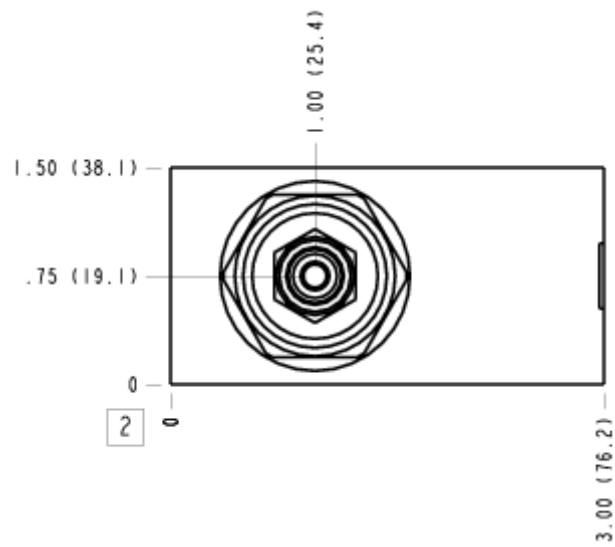

FACE 5

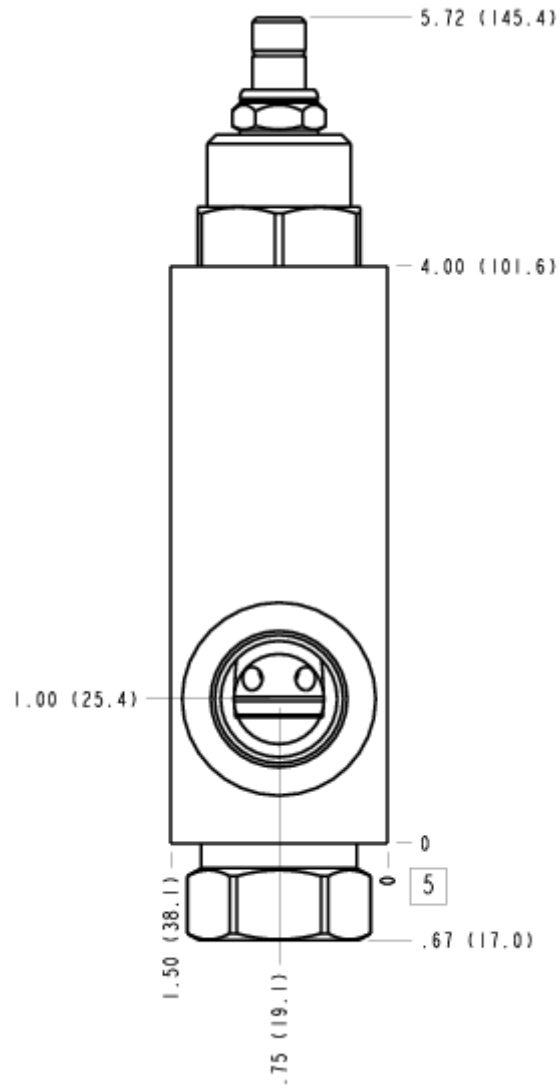

FACE 6

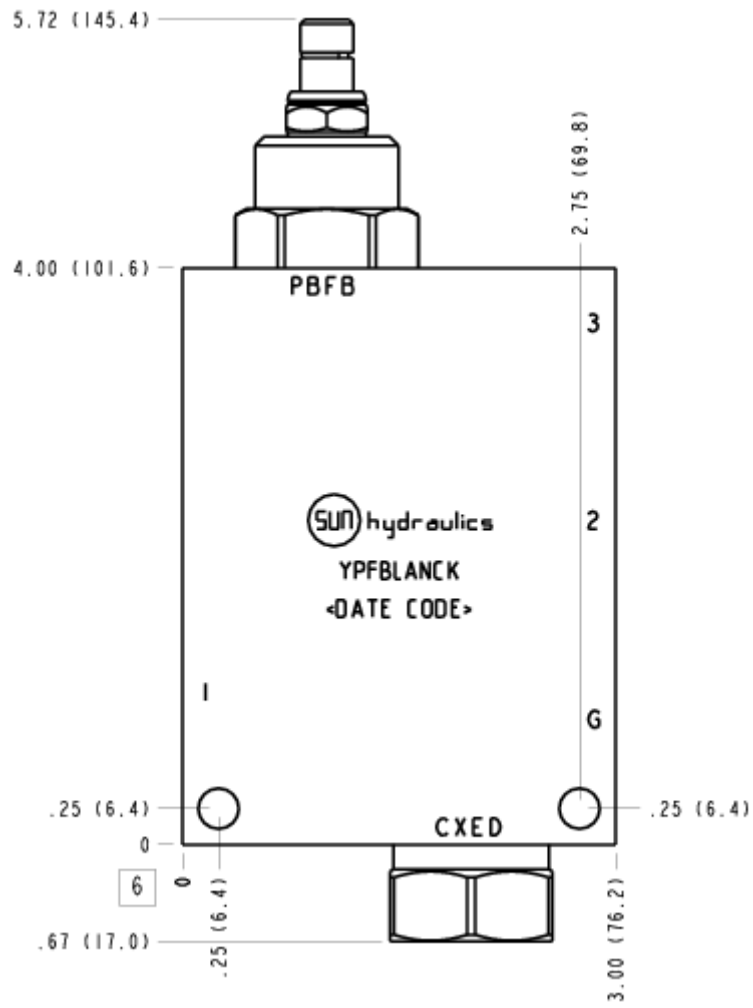

FACE 7

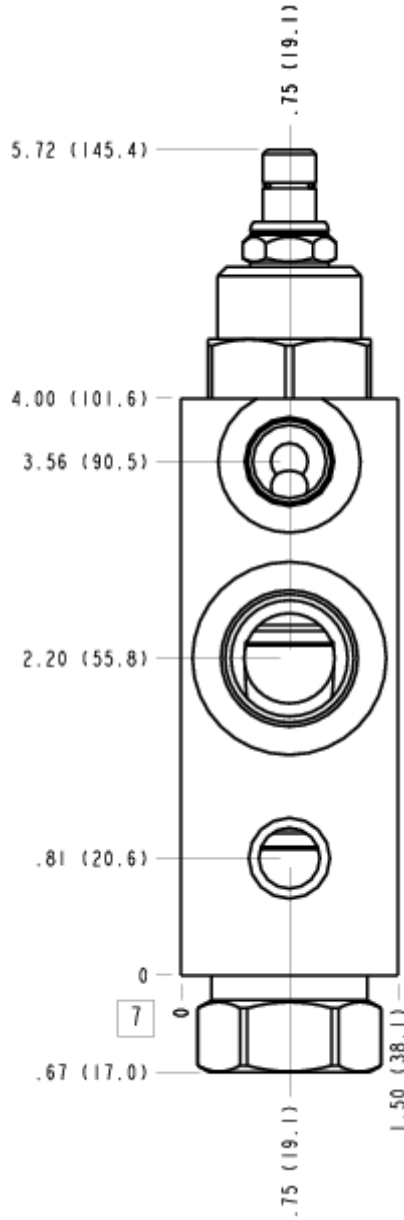

FACE 10

