

TECHNICAL DATA NOTE: DATA MAY VARY BY CONFIGURATION. SEE CONFIGURATION SECTION.

Body Type	montaje en línea
Capacity	240 L/min.
Mounting Hole Quantity	2

OPTION SELECTION EXAMPLE: YRGJLANAE

CONTROL	(L) ADJUSTMENT RANGE	(A) SEAL MATERIAL	(N)
L Standard Screw Adjustment	A 100 - 3000 psi (7 - 210 bar), 1000 psi (70 bar) Standard Setting	N Buna-N	
C Tamper Resistant - Factory Set	B 50 - 1500 psi (3,5 - 105 bar), 1000 psi (70 bar) Standard Setting	V Viton	
J Capped Screw Adjustment	D 25 - 800 psi (1,7 - 55 bar), 400 psi (28 bar) Standard Setting		
K manilla	E 25 - 400 psi (1,7 - 28 bar), 200 psi (14 bar) Standard Setting		
	J 25 - 1500 psi (1,7 - 105 bar), 1000 psi (70 bar) Standard Setting		
	K 75 - 1500 psi (5 - 105 bar), 1000 psi (70 bar) Standard Setting		
	S 25 - 200 psi (1,7 - 14 bar), 100 psi (7 bar) Standard Setting		
	W 150 - 4500 psi (10,5 - 315 bar), 1000 psi (70 bar) Standard Setting		

PRIMARY CARTRIDGE (A)

A	A (with RPGC primary cartridge, Pilot-operated, pistón balanceado alivio válvula)
A	A (with RPGC3 primary cartridge, No-adjustable pilot-operated, pistón balanceado alivio válvula)
A	A (with RPGC8 primary cartridge, Pilot-operated, pistón balanceado alivio módulo principal con cavidad de control T-8A integral)

INCLUDED COMPONENTS

Part	Description	Quantity
CBGALIN	Cartridge	1
CXHAXCN	Cartridge	1
RPGCLAN	Cartridge - Primary	1

PERFORMANCE CURVES

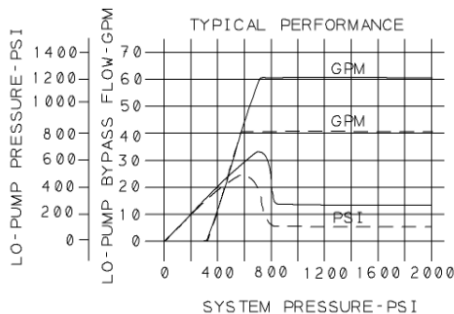

MANIFOLD FACES

FACE GRID

1	2	3	4
5	6	7	8
9	10	11	12

FACE 2

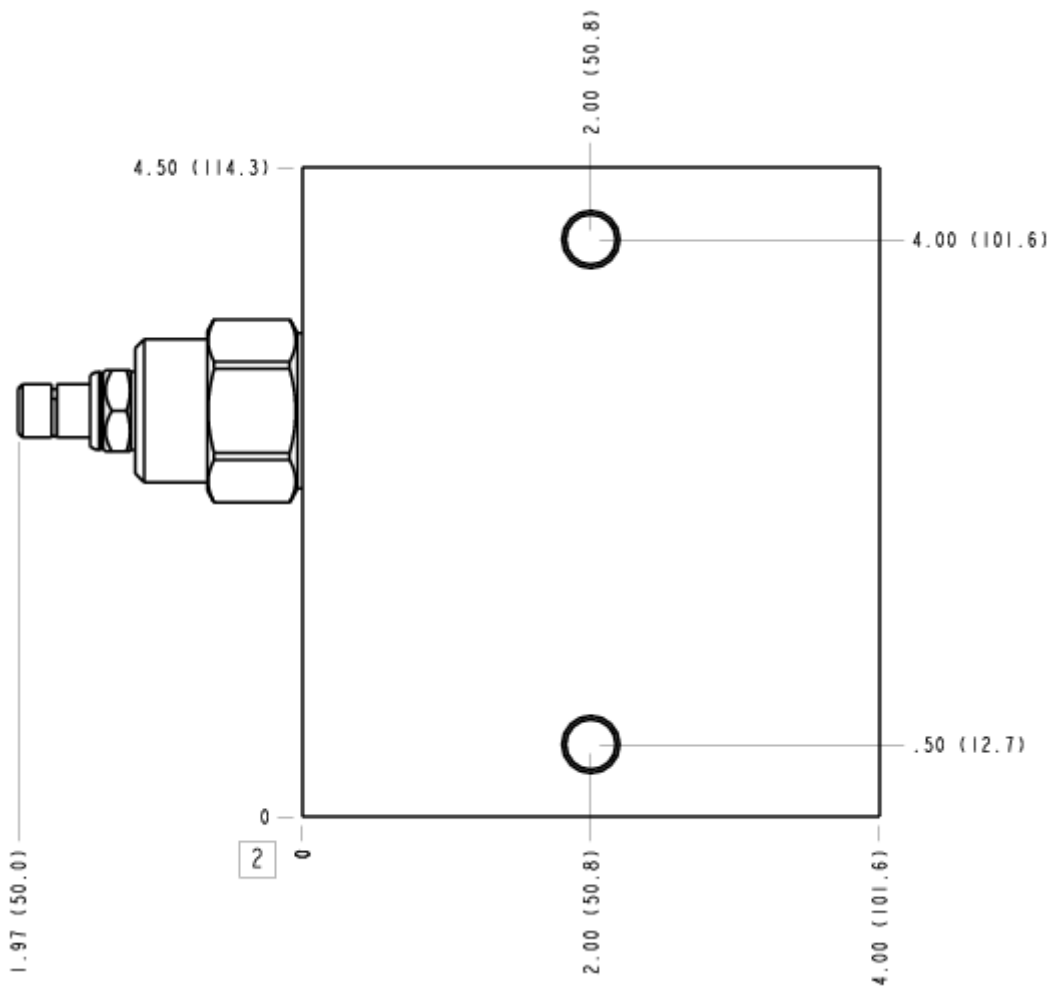

FACE 5

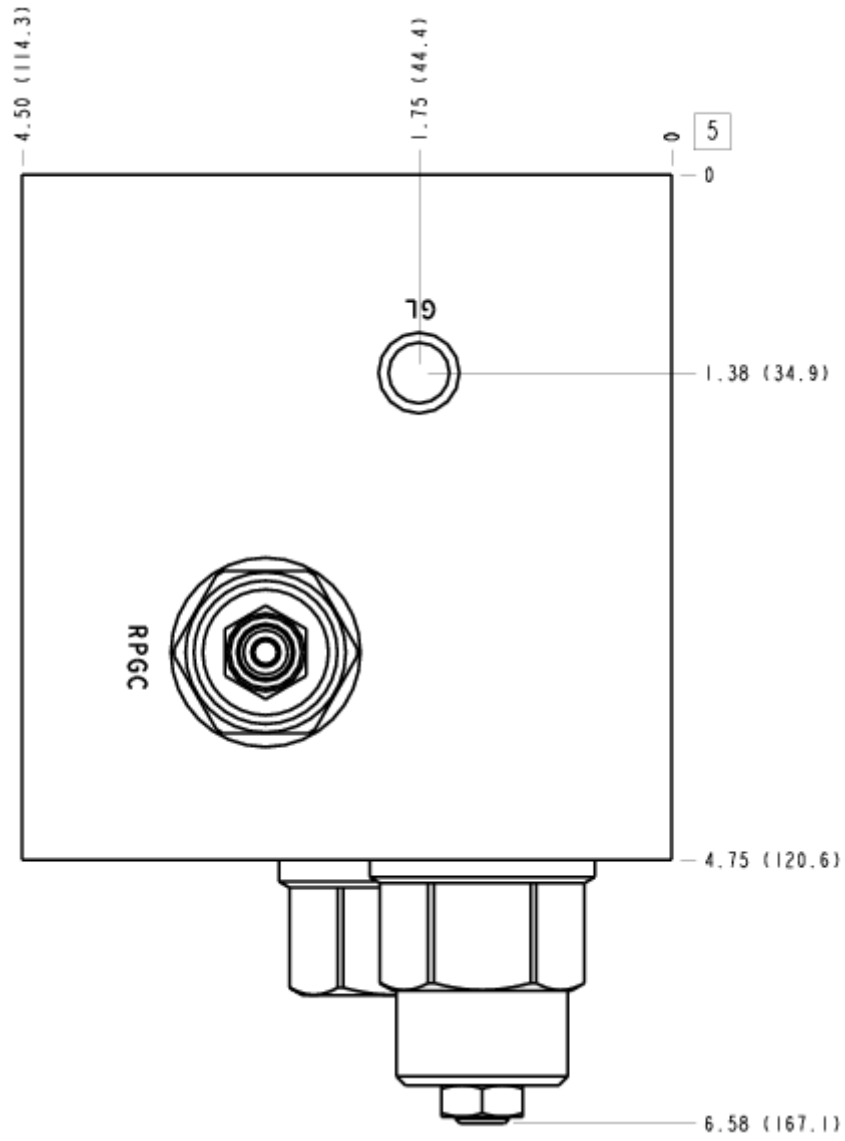

FACE 7

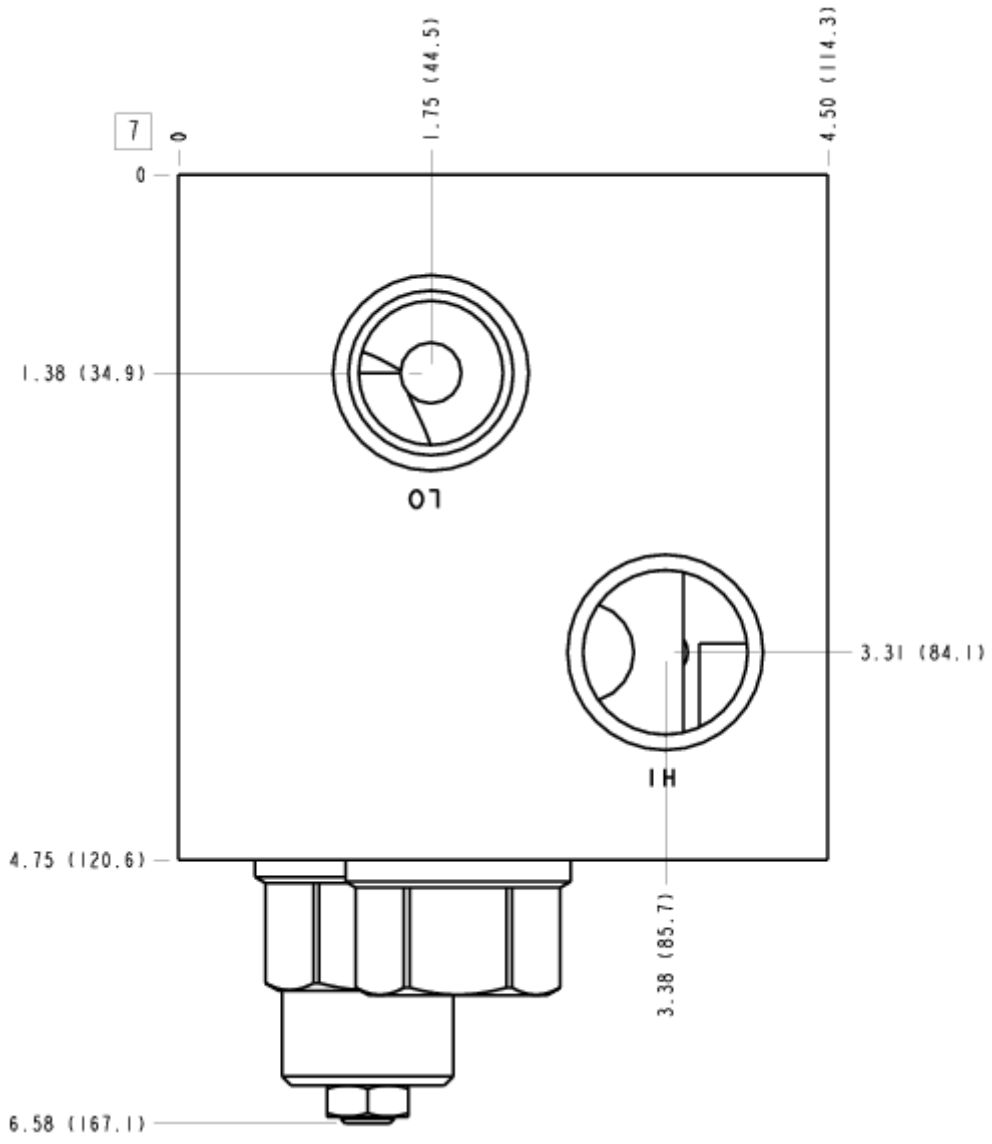

FACE 8

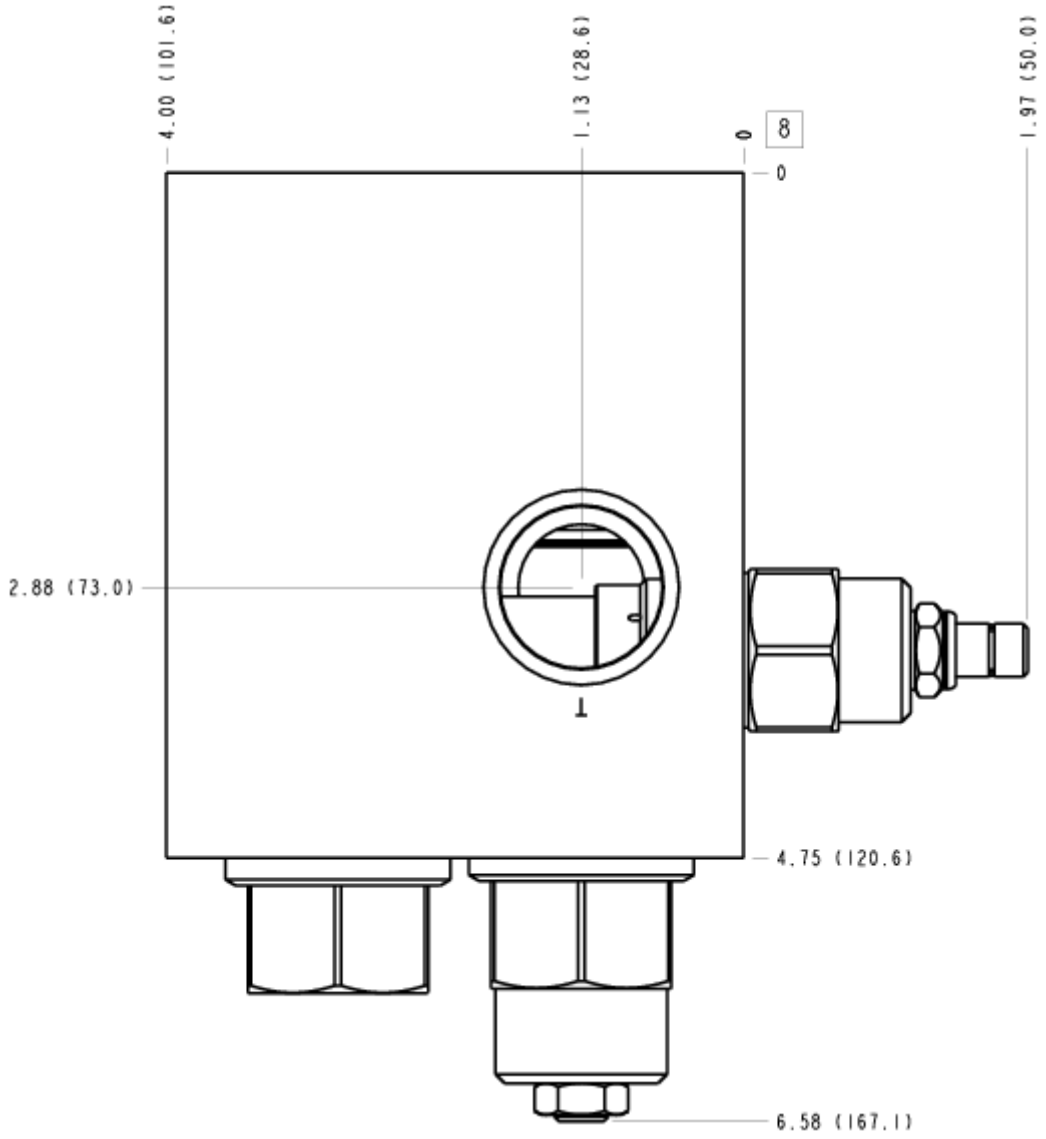

FACE 10

