

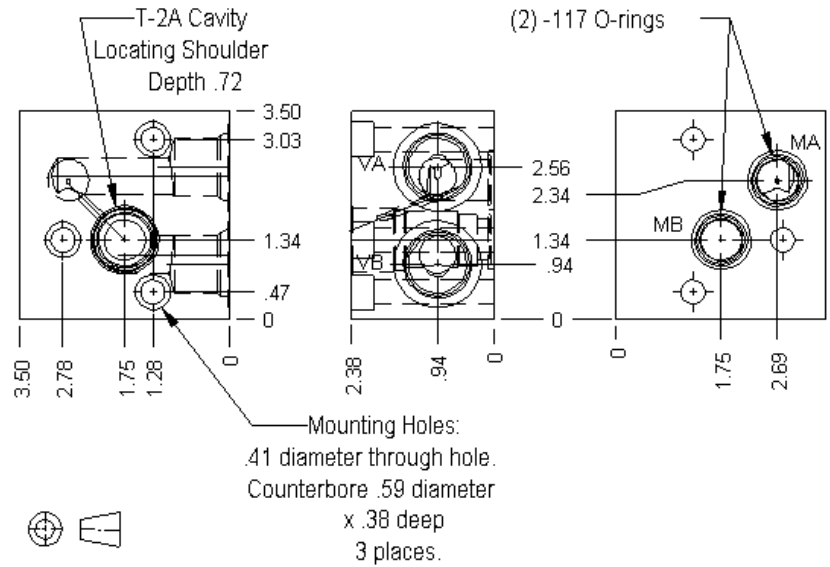

CONFIGURATION

Modifier



NOTES: • **Important:** Carefully consider the maximum system pressure. The pressure rating of the manifold is dependent on the manifold material, with the port type/size a secondary consideration. Manifolds constructed of aluminum are not rated for pressures higher than 3000 psi (210 bar), regardless of the port type/size specified.

MODIFIER

(Y3)

- /Y3** 65-45-12 Ductile Iron, Viton, Trivalent Clear Zinc with Top Sealer
6061-T651 Aluminum, Buna-N
- /11** 6061-T651 Aluminum, Buna-N, Clear Anodize - Per MIL SPEC 8625F Type II, Class I
- /10** 6061-T651 Aluminum, Buna-N, Black Anodize - Per MIL SPEC 8625F Type II, Class II
- /V** 6061-T651 Aluminum, Viton
- /16** 6061-T651 Aluminum, Viton, Clear Anodize - Per MIL SPEC 8625F Type II, Class I
- /15** 6061-T651 Aluminum, Viton, Black Anodize - Per MIL SPEC 8625F Type II, Class II
- /S** 65-45-12 Ductile Iron, Buna-N, Dewatering Oil
- /S4** 65-45-12 Ductile Iron, Buna-N, Chem. Black
- /S3** 65-45-12 Ductile Iron, Buna-N, Trivalent Clear Zinc with Top Sealer
- /Y** 65-45-12 Ductile Iron, Viton, Dewatering Oil
- /Y4** 65-45-12 Ductile Iron, Viton, Chem. Black