

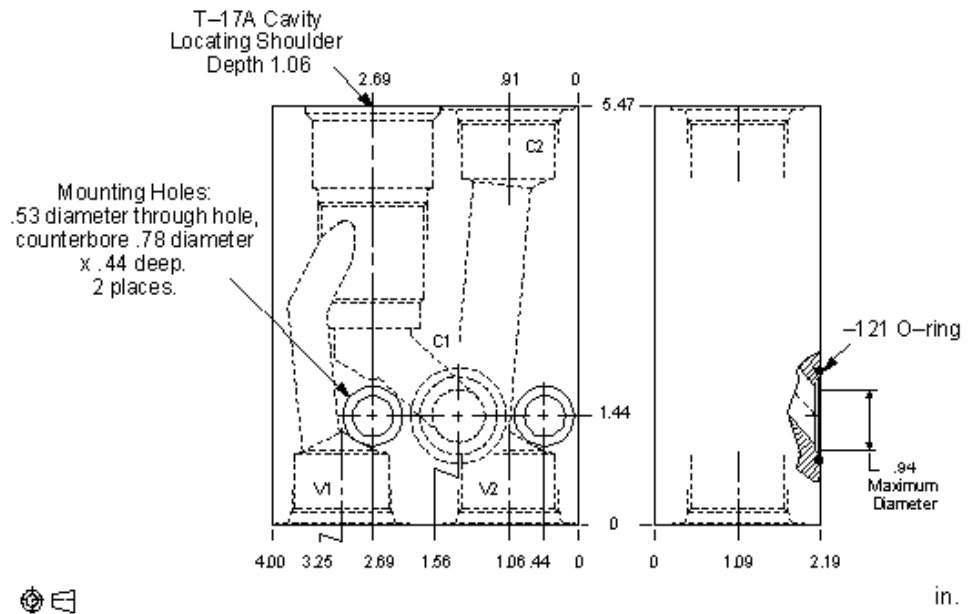

## CONFIGURATION

Modifier



**NOTES:** • **Important:** Carefully consider the maximum system pressure. The pressure rating of the manifold is dependent on the manifold material, with the port type/size a secondary consideration. Manifolds constructed of aluminum are not rated for pressures higher than 3000 psi (210 bar), regardless of the port type/size specified.

### MODIFIER

(/Y3)

**/Y3** 65-45-12 Ductile Iron, Viton, Trivalent Clear Zinc with Top Sealer

6061-T651 Aluminum, Buna-N

**/11** 6061-T651 Aluminum, Buna-N, Clear Anodize - Per MIL SPEC 8625F Type II, Class I

**/10** 6061-T651 Aluminum, Buna-N, Black Anodize - Per MIL SPEC 8625F Type II, Class II

**/V** 6061-T651 Aluminum, Viton

**/16** 6061-T651 Aluminum, Viton, Clear Anodize - Per MIL SPEC 8625F Type II, Class I

**/15** 6061-T651 Aluminum, Viton, Black Anodize - Per MIL SPEC 8625F Type II, Class II

**/S** 65-45-12 Ductile Iron, Buna-N, Dewatering Oil

**/S4** 65-45-12 Ductile Iron, Buna-N, Chem. Black

**/S3** 65-45-12 Ductile Iron, Buna-N, Trivalent Clear Zinc with Top Sealer

**/Y** 65-45-12 Ductile Iron, Viton, Dewatering Oil

**/Y4** 65-45-12 Ductile Iron, Viton, Chem. Black